

permacrete

CAPITALS / BASES



PERMACAP / PERMABASE

SPECIALIZED PRECAST COLUMN CAPITALS AND BASES FOR THE CONSTRUCTION INDUSTRY

Complimenting the **permacrete** range of columns, the **permacaps** and **permabases** have a hollow central core to enable the column to pass through the cap / base. This ensures accurate setting out and also reduces the structural moment points to two instead of four, as in conventional precast column bases and capitals.

These units can be ordered in either lightweight roto-moulded form made from our Mod 6 formulation, or in solid cast form made from our Mod 37 formulation.

Characteristics

- . Lightweight and easy to transport;
- . Smooth finish therefore no finishing plaster work
- . No need for filling or sanding
- . Strong and durable
- . 0% water absorption
- . UV stable & weather resistant

permacap

Technical Specifications

- . Mod 6 Natural Stone, resin bonded formulation
- . 8 Mpa flexural strength
- . 70 Mpa compressive strength
- . Lightweight (230mm diameter Capital = 5 kg)
- . Impervious to water - paint doesn't peel
- . Outstanding UV resistance
- . Resistant to biological attack

permabase

Technical Specifications

- . Mod 37 Natural Stone, resin bonded formulation
- . 25 Mpa flexural strength
- . 110 Mpa compressive strength
- . Lightweight (230mm diameter Base = 11 kg)
- . Impervious to water - paint doesn't peel
- . Outstanding UV resistance
- . High shock absorbency
- . Resistant to biological attack



PERMACAP ON 350mm DIAMETER PERMASTRUCT COLUMN

permacap / permabase DIMENSIONS (in mm)								
COLUMN SIZE	a	b	c	d	e	f	g	h
200	200	295	350	400	60	70	45	175
240	245	295	350	400	60	70	45	175
300	314	354	416	440	70	85	45	200
350	350	410	490	515	80	100	55	235
400	400	460	490	520	90	85	60	250
475	475	580	700	680	110	120	70	305

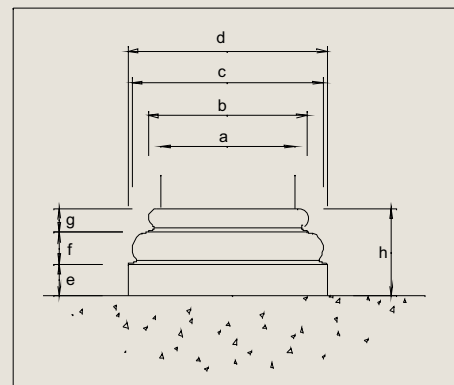

Visit our web-site at www.resocrete.co.za

Copyright - all information contained in this document is copyright and is the property of Resocrete