



Victoria Design

Introducing



*Moulding the Future*



Palisade Design

## resin polymer balustrading

**NO ROTTING - NO RUSTING - 10 YEAR WARRANTY**

**Nick 082 326-6813 - Henry 082 462-6303 - Paul 082 494-6149  
Office 0861 377-703**

### **Characteristics:**

- . More economical than Steel, Wood or Aluminum
- . Maintenance free
- . Modular system, therefore quick, easy and hassle free installation
- . A wide range of designs to choose from
- . Impervious to water, therefore paint will not bubble or peel.



Bali Brite Design



Panorama Design



Oceana Design



Caribbean Design



Wozani Design



Herringbone-cross Design



Majestic Design

Our **balucrete** range consists of a spectrum of modular Balustrade products, which, through unique design and assembly innovations, results in quick installation, reducing erection time on site, and minimizing disruptions to the work place. Made from our unique resin polymer compound, with its superior structural and aesthetic characteristics, and outstanding fire rating, these systems result in low maintenance products, with all the beauty and deco-enhancing characteristic unique to the **resocrete** range of products.

Unlike comparative products, this system consists of a joint free pre-moulded central pattern, which is fitted between the Handrail and the Base-rail into a channel cast under the Handrail. Components are bonded together using High Strength Epoxies, resulting in a product which will not crack, will not rust or corrode and which can be painted to the customers choice of finish. **resocrete**'s uses are almost endless. Conforming to industry safety standards of lateral loading, height and dimensional tolerances, this low maintenance system offers the very best in design variation and functionality and is the ultimate solution for affordable Balustrading and fencing.

### Residential projects, contracts and developments:

- Manhattan Mews - Umhlanga New Town Centre
- Mt Edgecombe Country Club Estate
- Le Domaine retirement village
- Zimbali Forest and Golf Estate
- Somerset Valley Retirement Village
- Camelot Estate; Prince's Grant
- Lanarco Estate; Wozani Ridge
- Caribbean Estate - Port Edward
- Kirklington Estate; Wakenshaw Estate
- Pentyre Point; Horizon View
- Ridgeton Towers
- Warner Doons - Amanzimtoti
- Langford Country Estate



Estates Caribbean Design



Estates Palisade Design



Wozani Design



Balie Wall Design

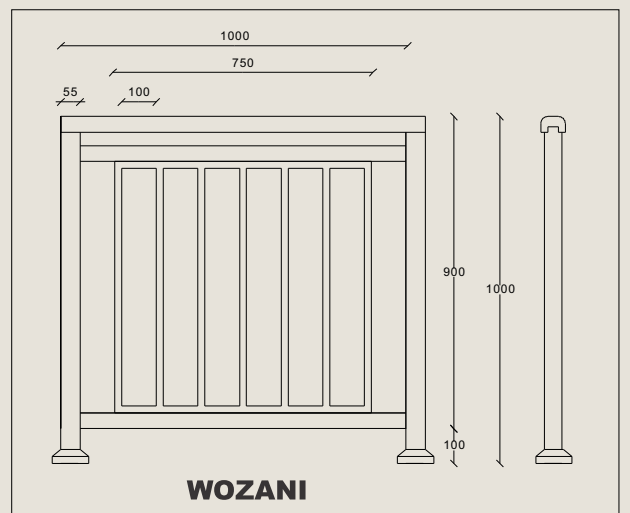
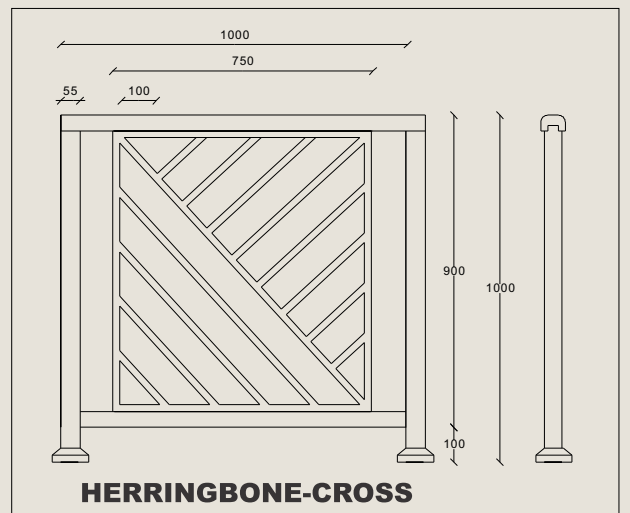
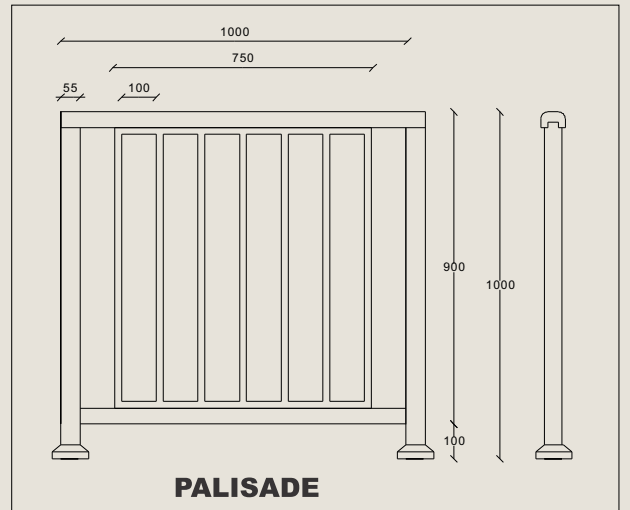
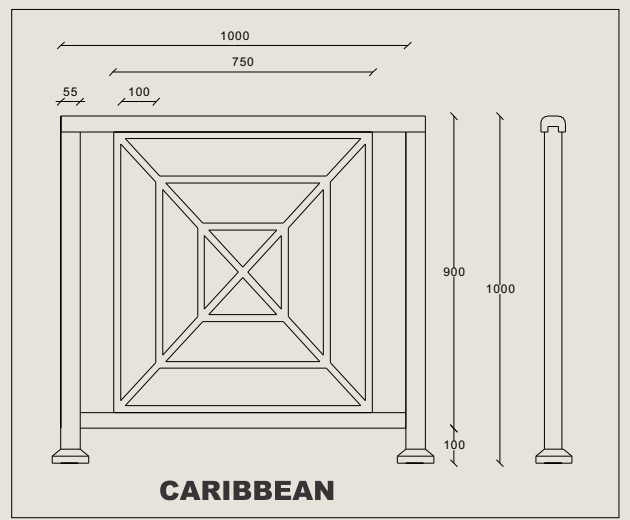

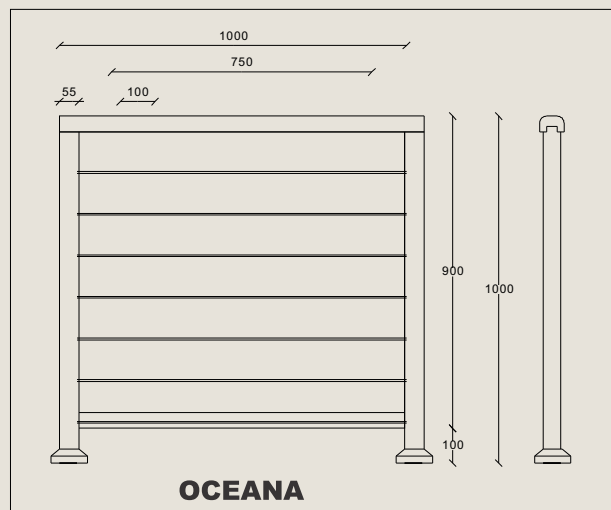
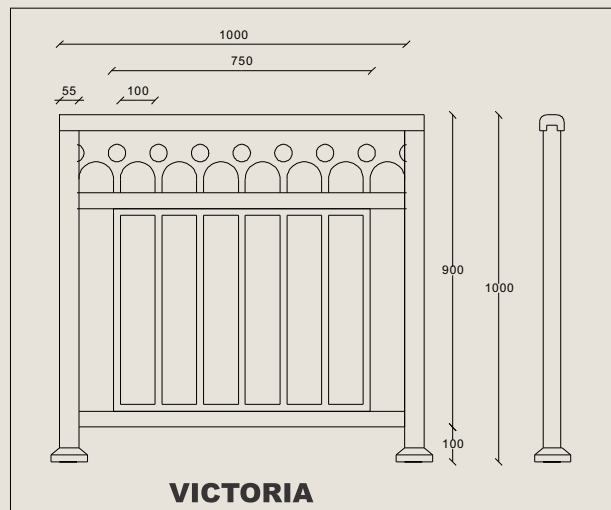
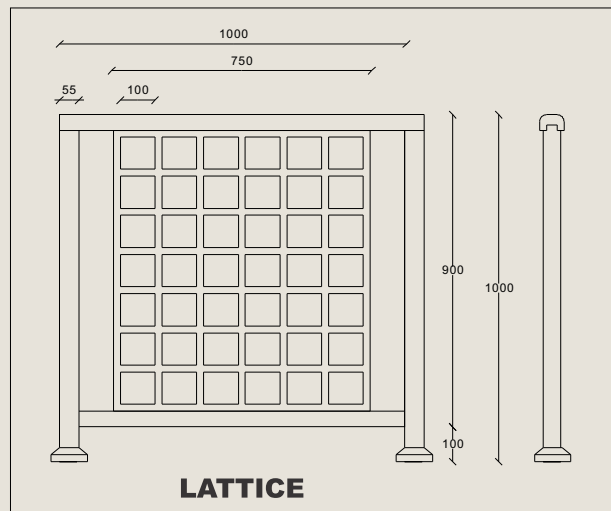
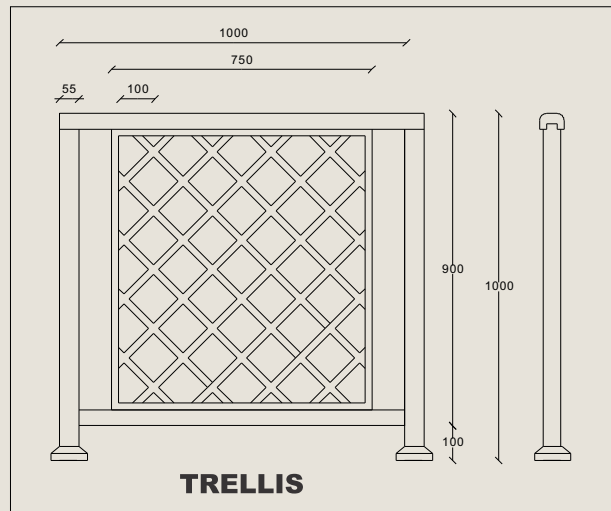

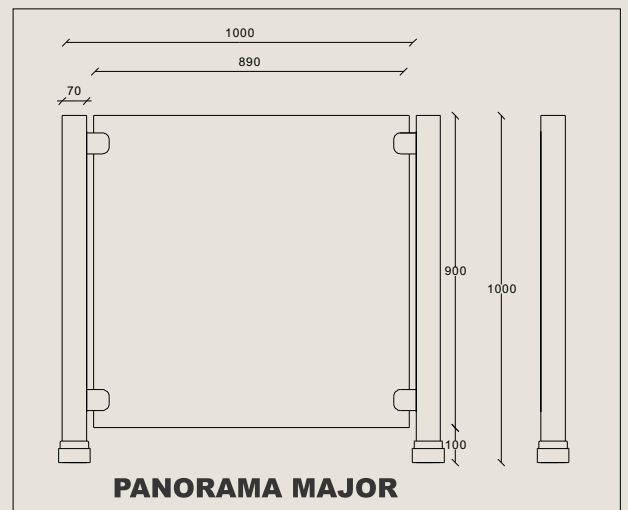
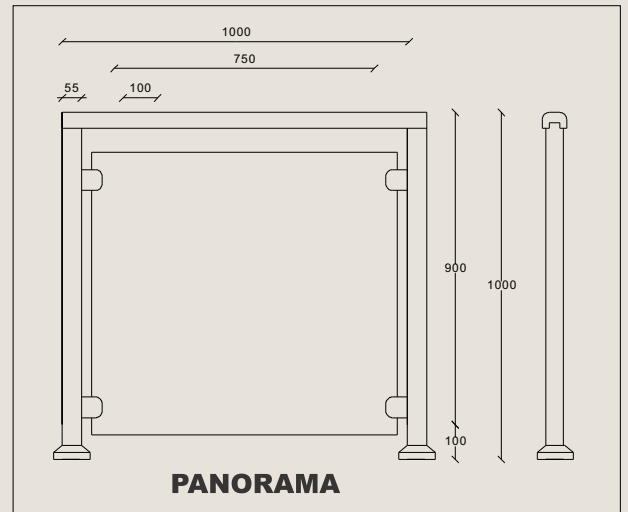
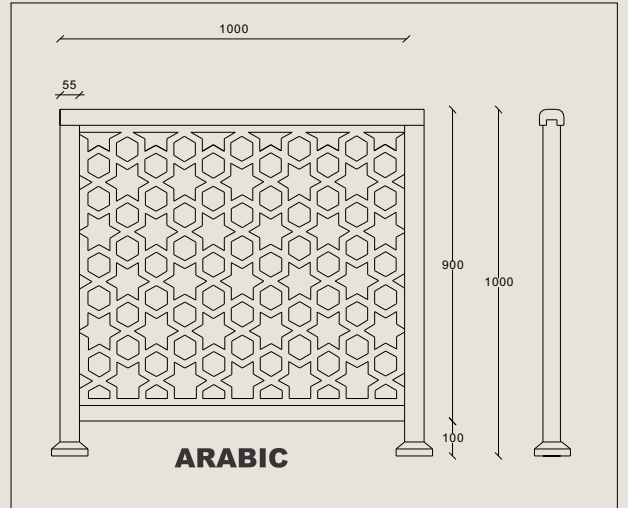
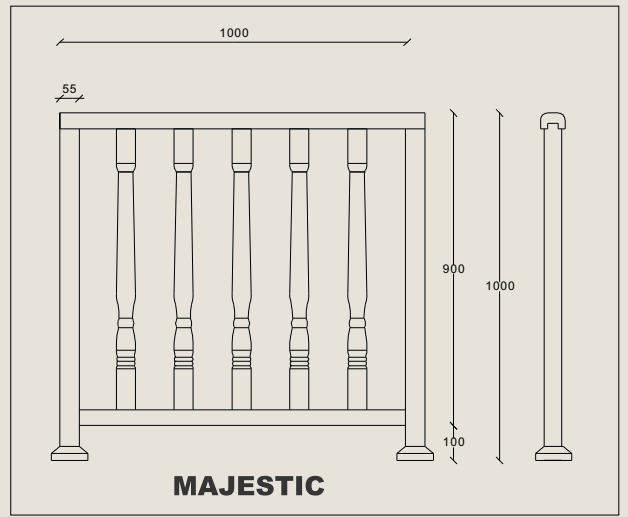

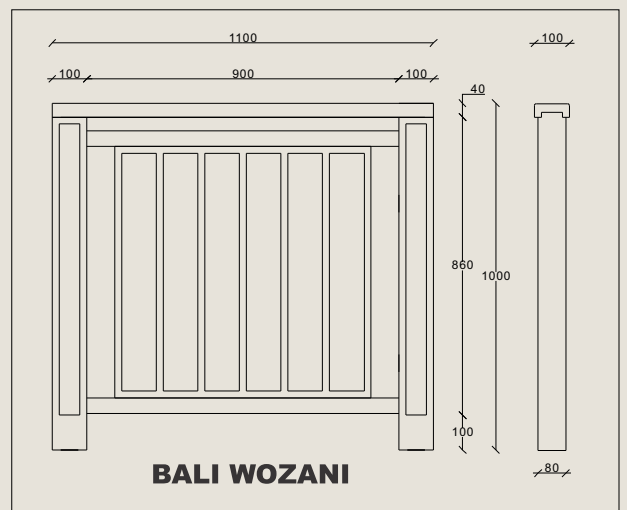
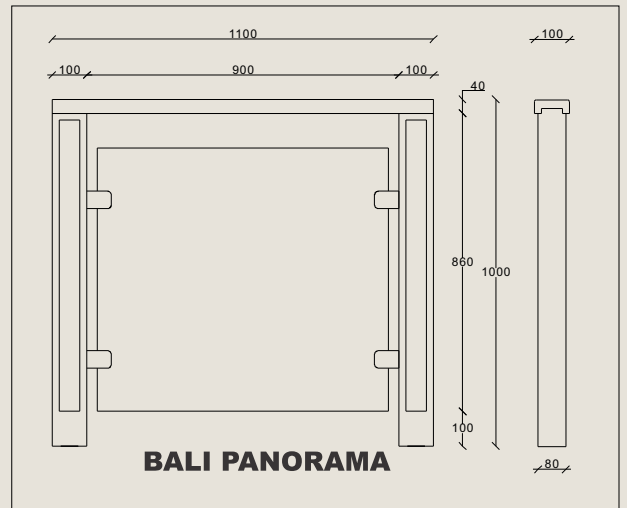
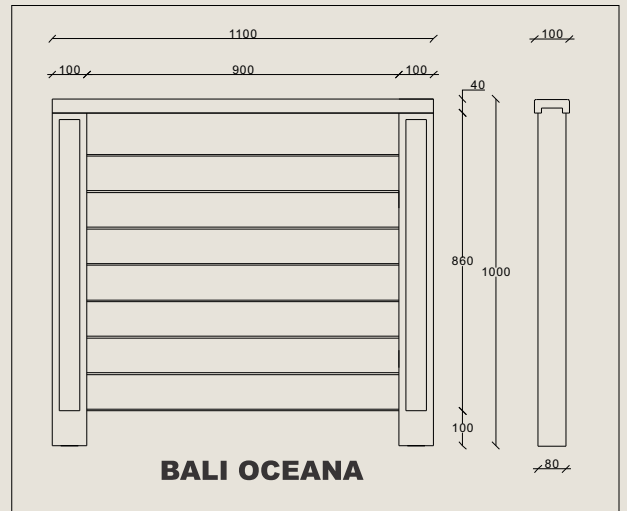
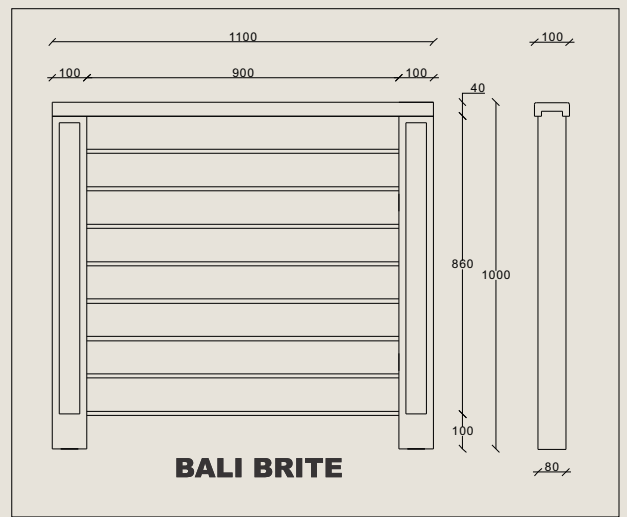

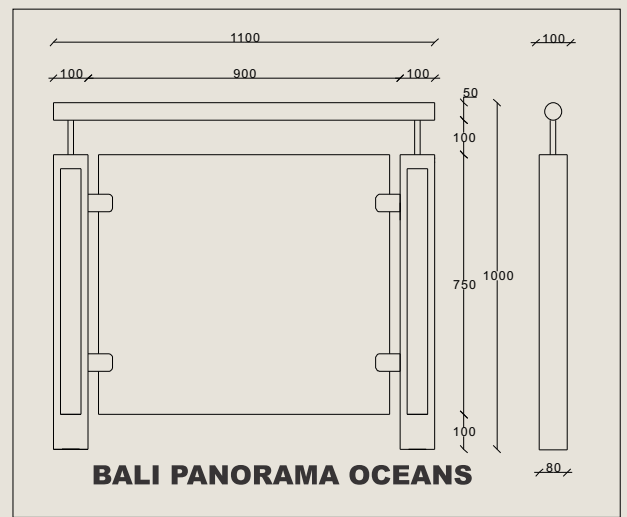

The **Panorama Grande** makes stair cases flair with style and can be adapted to incorporate stainless steel handrails



The resourcefulness of the **Bali** range is almost endless.

Here our **Bali Brite** range incorporates 12mm stainless steel tubing with wooden handrails.



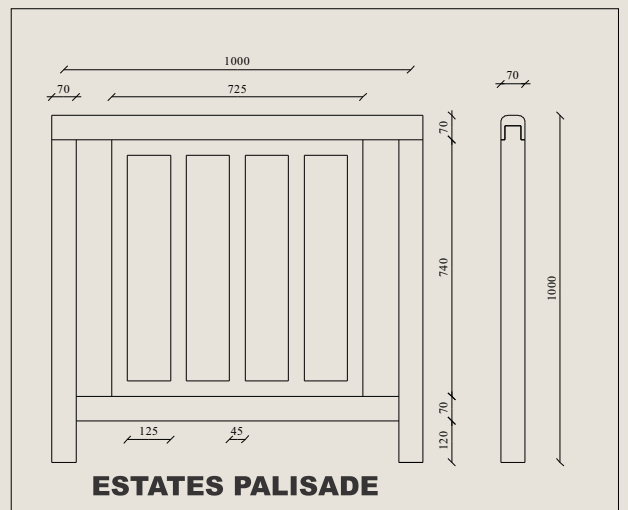
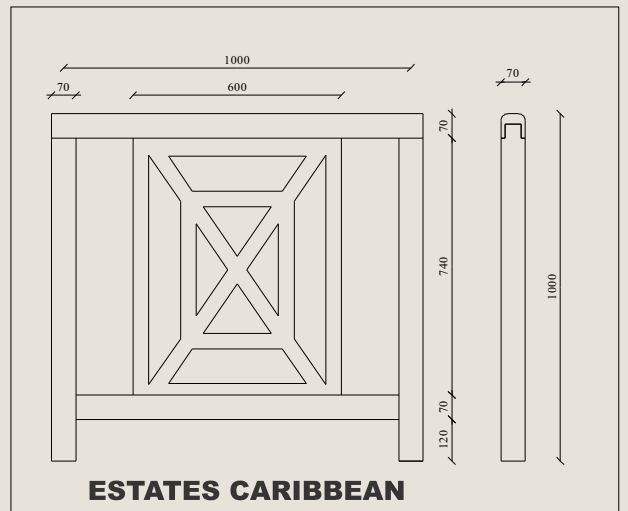
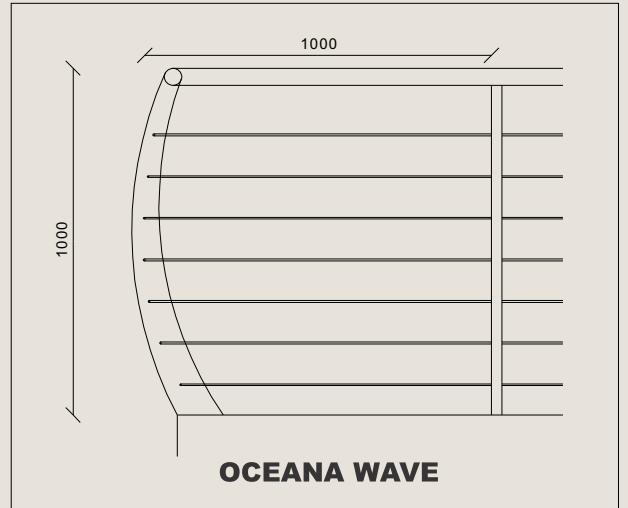
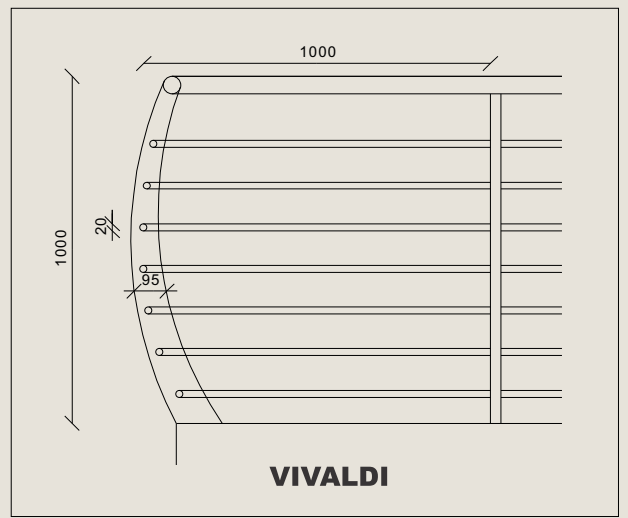

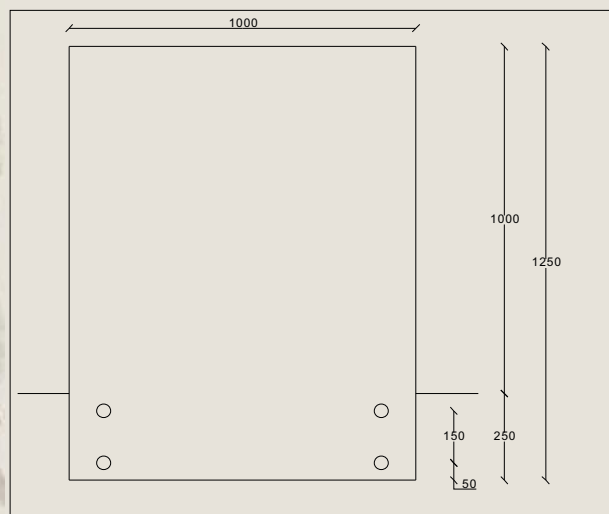
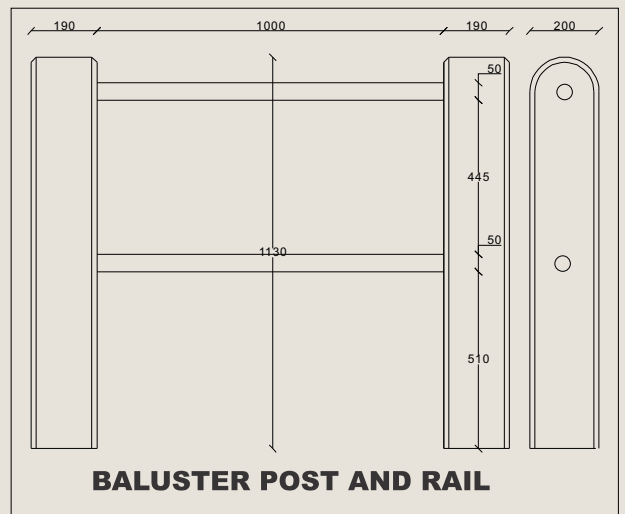
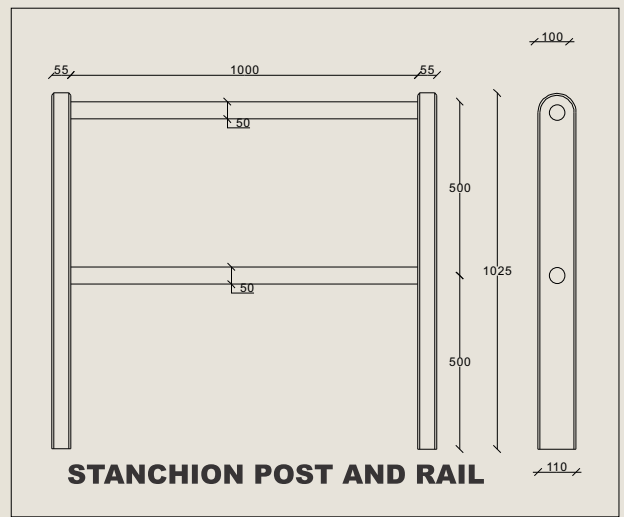

**PANORAMA FULL GLAZED SYSTEM  
PLAIN GLASS - PANORAMA COMMODORE  
WITH HANDRAIL - PANORAMA GRANDE**







**BLUE LAGOON BRIDGE - DURBAN**

**NATIONAL ROADS / BRIDGES HANDRAILS**

**REBAR LOCATOR SYSTEM**

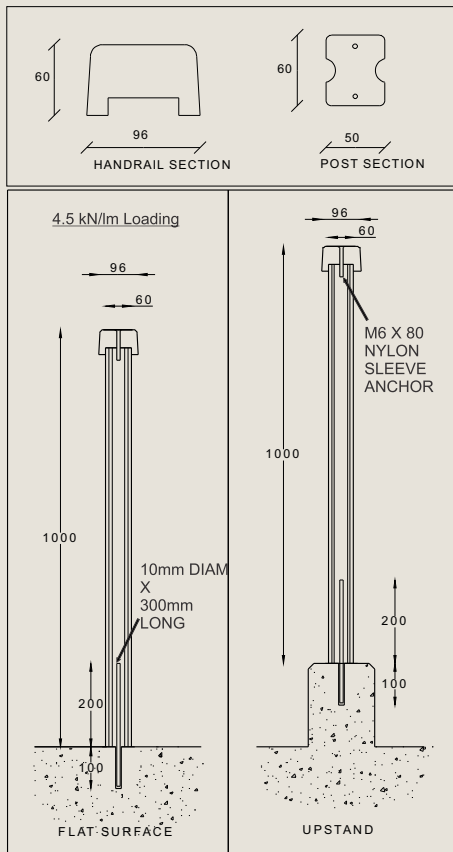

**NATIONAL ROADS  
4.5 Kn/m LOADING**

**CONCRETE CORE OR GROOVE SYSTEM**

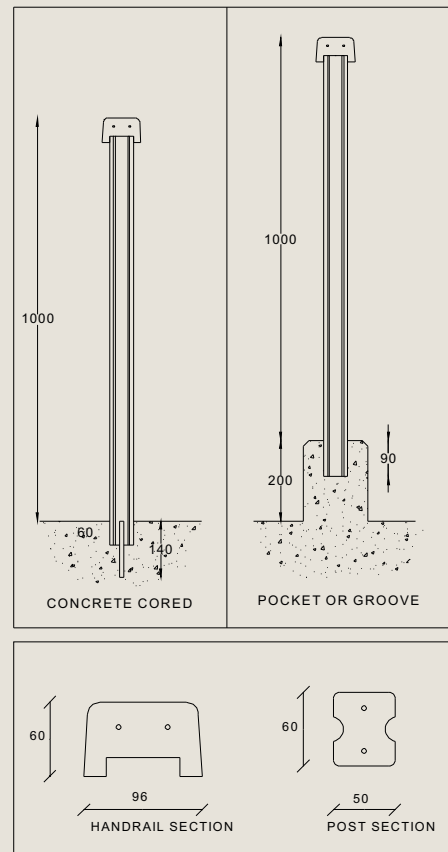

**NATIONAL ROADS  
4.5 Kn/m LOADING**